

vtech®

Instruction Manual

Toot-Toot Drivers®

4-in-1 Raceway



VTech understands that a child's needs and abilities change as they grow and with that in mind we develop our toys to teach and entertain at just the right level...

vtech Baby

Toys that will stimulate their interest in different textures, sounds and colours

I am...

...responding to colours, sounds and textures

...understanding cause and effect

...learning to touch, reach, grasp, sit-up, crawl and toddle

Birth-36 months



Pre-School

Interactive toys to develop their imagination and encourage language development

I want...

...to get ready for school by starting to learn the alphabet and counting

...my learning to be as fun, easy and exciting as can be

...to show my creativity with drawing and music so my whole brain develops

3-6 years



Electronic Learning Computers

Cool, aspirational and inspiring computers for curriculum related learning

I need...

...challenging activities that can keep pace with my growing mind

...intelligent technology that adapts to my level of learning

...National Curriculum based content to support what I'm learning at school

4-10 years



To learn more about this and other VTech® products, visit www.vtech.co.uk

INTRODUCTION

Thank you for purchasing the **VTech® Toot-Toot Drivers® 4-in-1 Raceway**.

Get racing with the 4-in-1 Raceway by VTech®! 4 different track configurations open up a world of racing and stunt play. Choose from a zigzag, super long ramp, duel raceway and 2-car raceway and let the racing commence!

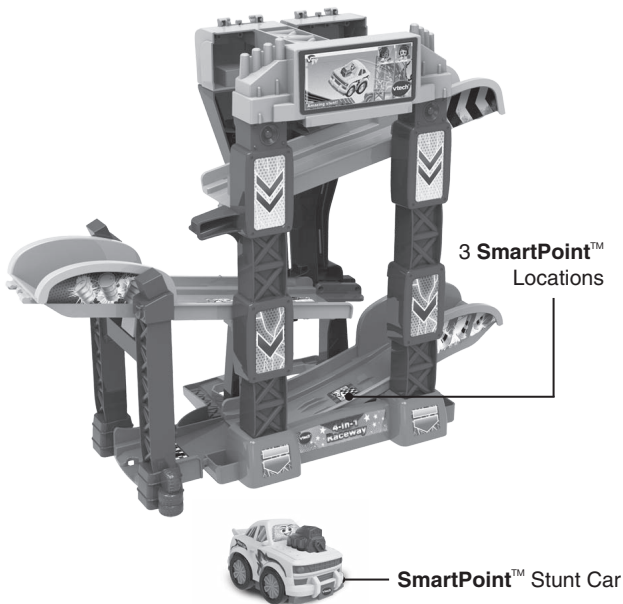

INCLUDED IN THIS PACKAGE



One **SmartPoint™**
stunt car



A



B



C



D

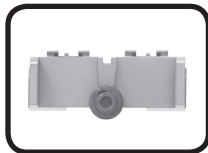

E



F



G



H



I



J



K

- Label Sheet
- Quick Start Guide

WARNING:

All packing materials such as tape, plastic sheets, packaging locks, removable tags, cable ties, cords and packaging screws are not part of this toy and should be discarded for your child's safety.

NOTE:

Please save this Instruction Manual as it contains important information.

If there are no locks inside the package, disregard this message.

Removing the Packaging Locks:

- ① Turn the packaging locks anticlockwise several times.
- ② Pull out the packaging locks and discard.

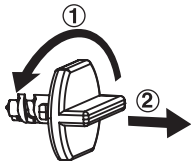

INSTRUCTIONS

Battery Removal And Installation Stunt Car

1. Make sure the unit is turned **OFF**.
2. Locate the battery cover on the bottom of the Stunt Car. Use a screwdriver to loosen the screw and then open the battery cover.
3. If used batteries are present, remove from the unit by pulling up on one end of each battery.
4. Install 2 new AAA (AM-4/LR03) batteries following the diagram inside the battery box. (For best performance, alkaline batteries or fully charged Ni-MH rechargeable batteries are recommended).
5. Replace the battery cover and tighten the screw to secure.

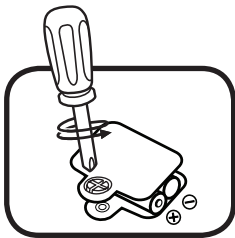

WARNING:

Adult assembly required for battery installation.
Keep batteries out of reach of children.

IMPORTANT: BATTERY INFORMATION

- Insert batteries with the correct polarity (+ and -).
- Do not mix old and new batteries.
- Do not mix alkaline, standard (carbon-zinc) or rechargeable batteries.
- Only batteries of the same or equivalent type as recommended are to be used.
- Do not short-circuit the supply terminals.
- Remove batteries during long periods of non-use.
- Remove exhausted batteries from the toy.
- Dispose of batteries safely. Do not dispose of batteries in fire.

RECHARGEABLE BATTERIES:

- Remove rechargeable batteries from the toy before charging.
- Rechargeable batteries are only to be charged under adult supervision.
- Do not charge non-rechargeable batteries.

Disposal of batteries and product



The crossed-out wheellie bin symbols on products and batteries, or on their respective packaging, indicates they must not be disposed of in domestic waste as they contain substances that can be damaging to the environment and human health.

The chemical symbols Hg, Cd or Pb, where marked, indicate that the battery contains more than the specified value of mercury (Hg), cadmium (Cd) or lead (Pb) set out in the Batteries and Accumulators Regulation.



The solid bar indicates that the product was placed on the market after 13th August, 2005.

Help protect the environment by disposing of your product or batteries responsibly.

VTech[®] cares for the planet.

Care for the environment and give your toy a second life by disposing of it at a small electricals collection point so all its materials can be recycled.

In the UK:

Visit www.recyclenow.com to see a list of collection points near you.

In Australia & New Zealand:

Check with your local council for kerbside collections.

LABEL APPLICATION

Please stick the labels to the play set as shown below:

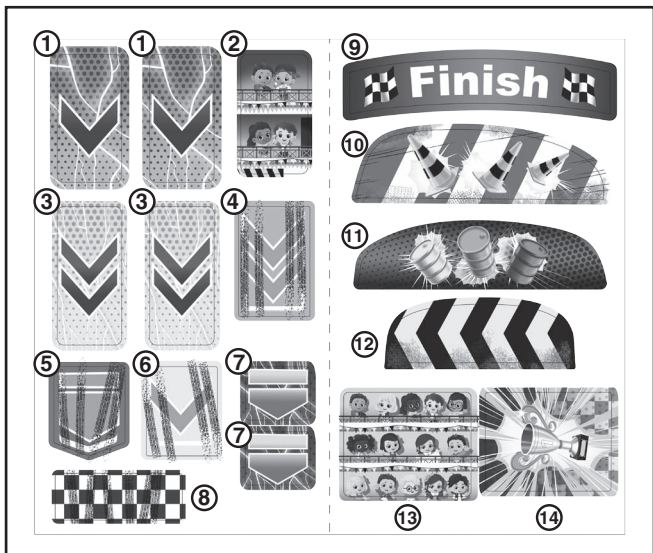

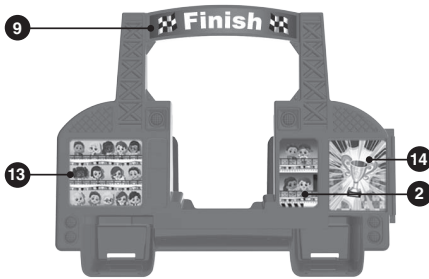
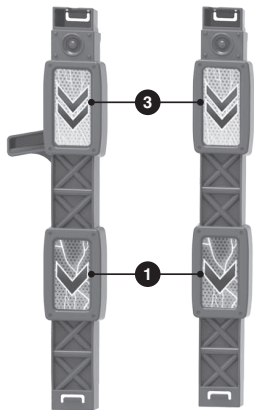

ASSEMBLY INSTRUCTIONS

With the **VTech® Toot-Toot Drivers® 4-in-1 Raceway**, safety comes first. To ensure your child's safety, adult assembly is required.

1. Insert B into A as shown below. Make sure you hear a click sound to confirm they are firmly connected.

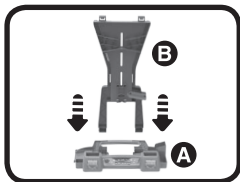

2. Insert C and D into A as shown below.

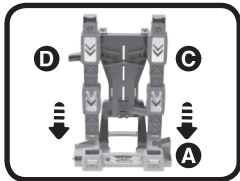

3. Insert E into B as shown below.

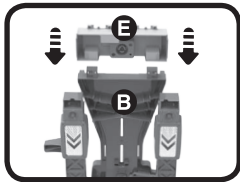

4. Insert F into C and D as shown below, then insert F into E as shown below. Once the above steps are completed, the main building is complete. And it can not be disassembled.

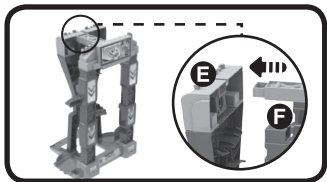
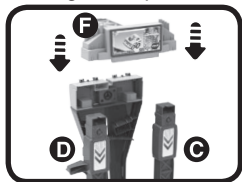

5. Slide down G into the second floor as shown below. Make sure you hear a pop sound to confirm G has been connected correctly.

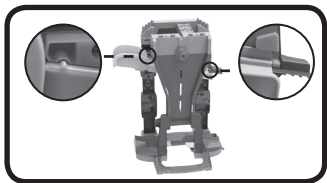
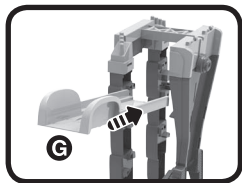

6. Connect H and I as shown below. Then connect them into A as shown below. Make sure you hear a click sound to confirm they are firmly connected.

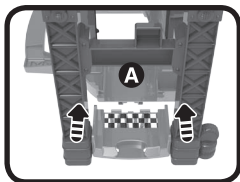
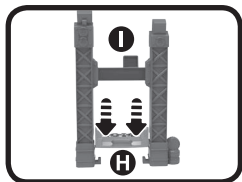

7. Slide down J into the first floor, and insert J into I and B and D as shown below.

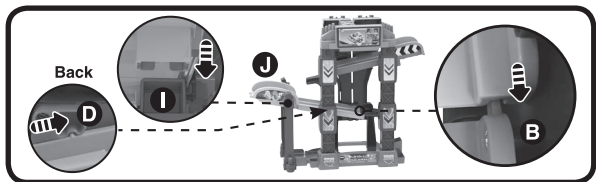

8. Slide down K to the ground floor, and insert K into A as shown below.

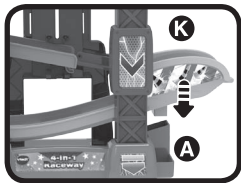

Once you've completed the above steps, you are ready to play! You can also connect the play set to other **Toot-Toot Drivers®** play sets (each sold separately).



TRANSFORMATION

2-Car Raceway

1. Disassemble J, K, G, H and I, then, lay down the main building as shown below.

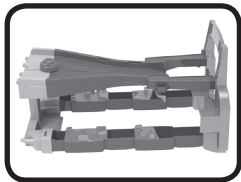

2. Insert J and G into I, then connect with E as shown below.

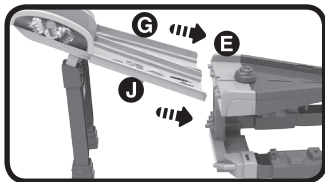
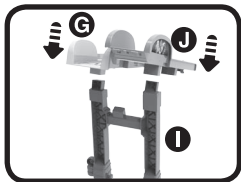

3. Connect H to K, then connect K to B.

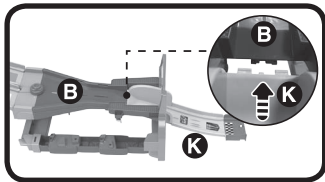
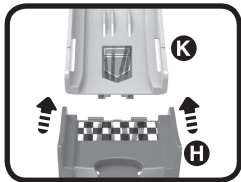

Once you've completed the above steps, the 2-car raceway is ready to play.

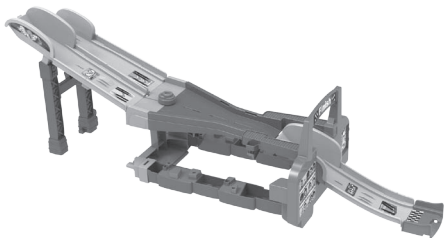

Duel Raceway

1. Disassemble J, K, G, H and I. Slide down G to the second floor,

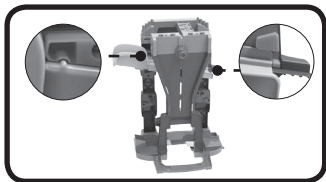
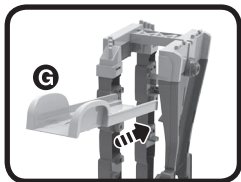

2. Insert I into J, then slide down J to the first floor as shown below.

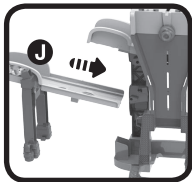
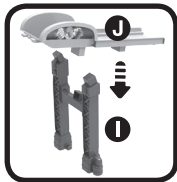

3. Connect K with J, connect H with K as shown below. Make sure you hear a click sound to confirm they are firmly connected.

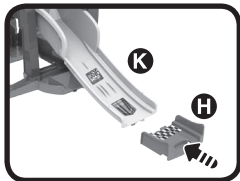
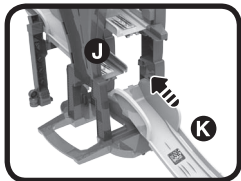

Once you've completed the above steps, the duel raceway is ready to play.

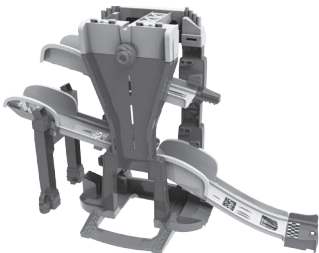

Super Long Ramp

1. Disassemble J, K, G, H and I. Slide down G to the second floor as shown below.

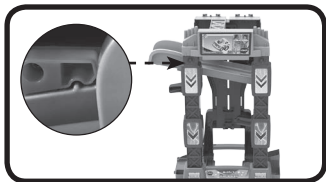
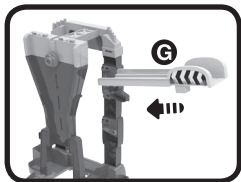

2. Connect J with G, insert I into J as shown below.

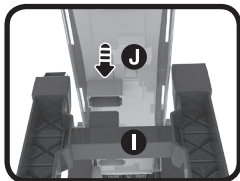
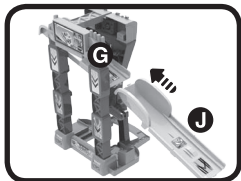

3. Connect K with J, connect H with K as shown below.

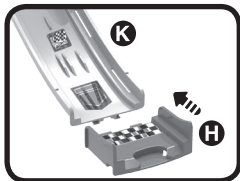
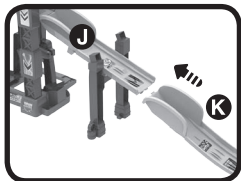

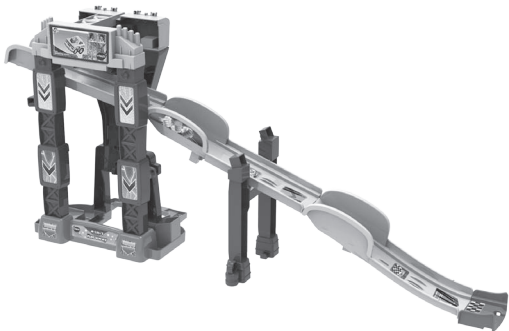

Once you've completed the above steps, the super long ramp is ready to play.



PRODUCT FEATURES

1. On/Off Switch

To turn the unit **On**, slide the **On/Off Switch** to the **On** () position. To turn the unit **Off**, slide the **On/Off Switch** to the **Off** () position.

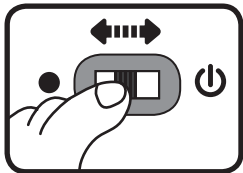

2. Automatic Shut-Off

To preserve battery life, the **Toot-Toot Drivers® Stunt Car** will automatically power down after approximately 60 seconds without input. The unit can be turned on again by pressing the light up button or the engine button, pushing the car quickly, or triggering a **SmartPoint™** location.

Note: This product is in try-me mode in the packaging. After opening the package, turn the vehicle off and on again to proceed with normal play. If the unit repeatedly powers down while playing, please install a new set of batteries.

ACTIVITIES

Stunt Car

1. Slide the **On/Off Switch** to turn the Stunt Car **On**. You will hear a song, phrases and sounds. The light will flash with the sounds.

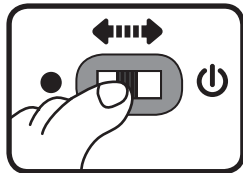

2. Press the **Light Up Button** to hear fun sounds, songs, phrases and melodies. The light will flash with the sounds.



3. Press the **Engine Button** to hear fun sounds and phrases. Lights will flash with the sounds.



4. Push the Stunt Car quickly to hear fun sounds. If a melody is already playing, push the Stunt Car to add fun sounds on top of the melody. Lights will flash with the sounds.



5. For added fun, the **Stunt Car** interacts with the **VTech® Toot-Toot Drivers® 4-in-1 Raceway**. Simply place the Stunt Car on one of the three **SmartPoint™** locations to hear fun sounds, phrases and see the light flash. The Stunt Car also interacts with other **Toot-Toot Drivers®** play sets (each play set sold separately).



ACTIVITIES

4-in-1 Raceway

1. Place the Stunt Car or any **SmartPoint™** vehicle (each sold separately) on any of the three **SmartPoint™** locations to trigger fun sounds, songs or phrases.



2. Put the Stunt Car on the **SmartPoint™** starting line, then release and watch it race to the bottom.



3. Easily re-configure the play set, between zigzag, super long ramp, duel raceway and 2-car raceway.

MELODY LIST

1. Fur Elise
2. Did You Ever See a Lassie
3. For He's a Jolly Good Fellow
4. Funiculi, Funicula
5. London Bridge
6. McNamara's Band

SONG LIST

Song 1

Get ready for an amazing show,
My engine can't wait to roar.
Ready to jump and good to go
Three two one, this is amazing.

Song 2

Here we go loopy loop
Here we go spinny spin
Here we go round the track
I know that I'm going to win!

Song 3

Toot! Toot! Drivers!
I'm a Toot! Toot! Drivers! Stunt Car.
Drifting is my favourite. (Toot! Toot!)
I can drift on straight tracks or on turns,
Let's Go! Go! and see! (Toot! Toot!)

CARE & MAINTENANCE

1. Keep the unit clean by wiping it with a slightly damp cloth.
2. Keep the unit out of direct sunlight and away from any direct heat sources.
3. Remove the batteries if the unit will not be in use for an extended period of time.
4. Do not drop the unit on hard surfaces and do not expose the unit to moisture or water.

TROUBLESHOOTING

If for some reason the program/activity stops working or malfunctions, please follow these steps:

1. Please turn the unit **Off**.
2. Interrupt the power supply by removing the batteries.
3. Let the unit stand for a few minutes, then replace the batteries.
4. Turn the unit **On**. The unit should now be ready to play with again.
5. If the product still does not work, install a brand new set of batteries.

CONSUMER SERVICES

Creating and developing **VTech®** products is accompanied by a responsibility that we at **VTech®** take very seriously. We make every effort to ensure the accuracy of the information, which forms the value of our products. However, errors sometimes can occur. It is important for you to know that we stand behind our products and encourage you to call our Consumer Services Department with any problems and/or suggestions that you might have. A service representative will be happy to help you.

UK Customers:

Phone: 0330 678 0149 (from UK) or +44 330 678 0149 (outside UK)

Website: www.vtech.co.uk/support

Australian Customers:

Phone: 1800 862 155

Website: support.vtech.com.au

NZ Customers:

Phone: 0800 400 785

Website: support.vtech.com.au

PRODUCT WARRANTY/ CONSUMER GUARANTEES

UK Customers:

Read our complete warranty policy online at vtech.co.uk/warranty.

Australian Customers:

VTECH ELECTRONICS (AUSTRALIA) PTY LIMITED –
CONSUMER GUARANTEES

Under the Australian Consumer Law, a number of consumer guarantees apply to goods and services supplied by VTech Electronics (Australia) Pty Limited. Please refer to vtech.com.au/consumerguarantees for further information.

**Visit our website for more
information about our products,
downloads, resources and more.**

www.vtech.co.uk
www.vtech.com.au

